

برق و صنعت سروین

کل جریان با ما

سیم، کابل و تجهیزات
برق صنعتی و ساختمانی

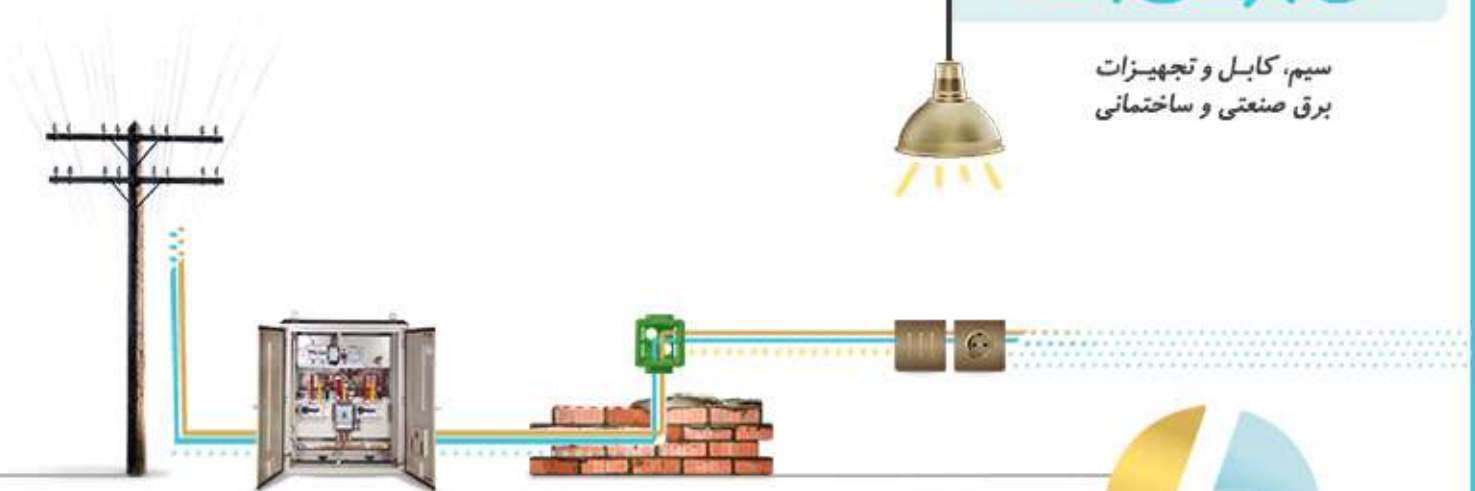

- ☎ ۰۲۱-۹۱۰ ۱۵ ۳۳۳ | ۰۲۱-۶۶ ۳۴۴۰ ۹۵
- 📍 دفتر مرکزی: تهران . لاله‌زار شمالی. پاساژ ایرانیان. طبقه دوم. واحد ۱۲۲
- ☎ ۰۸۶-۹۱۰ ۱۵ ۳۳۳
- 📍 اراک. خیابان شهید بهشتی. خیابان عضد. نبش عضد یک



w w w . b a r g h z o o m . c o m



ARSINI®

www.eai-co.com / eaindustry@yahoo.com

کل جریان با م



www.barghzoom.com

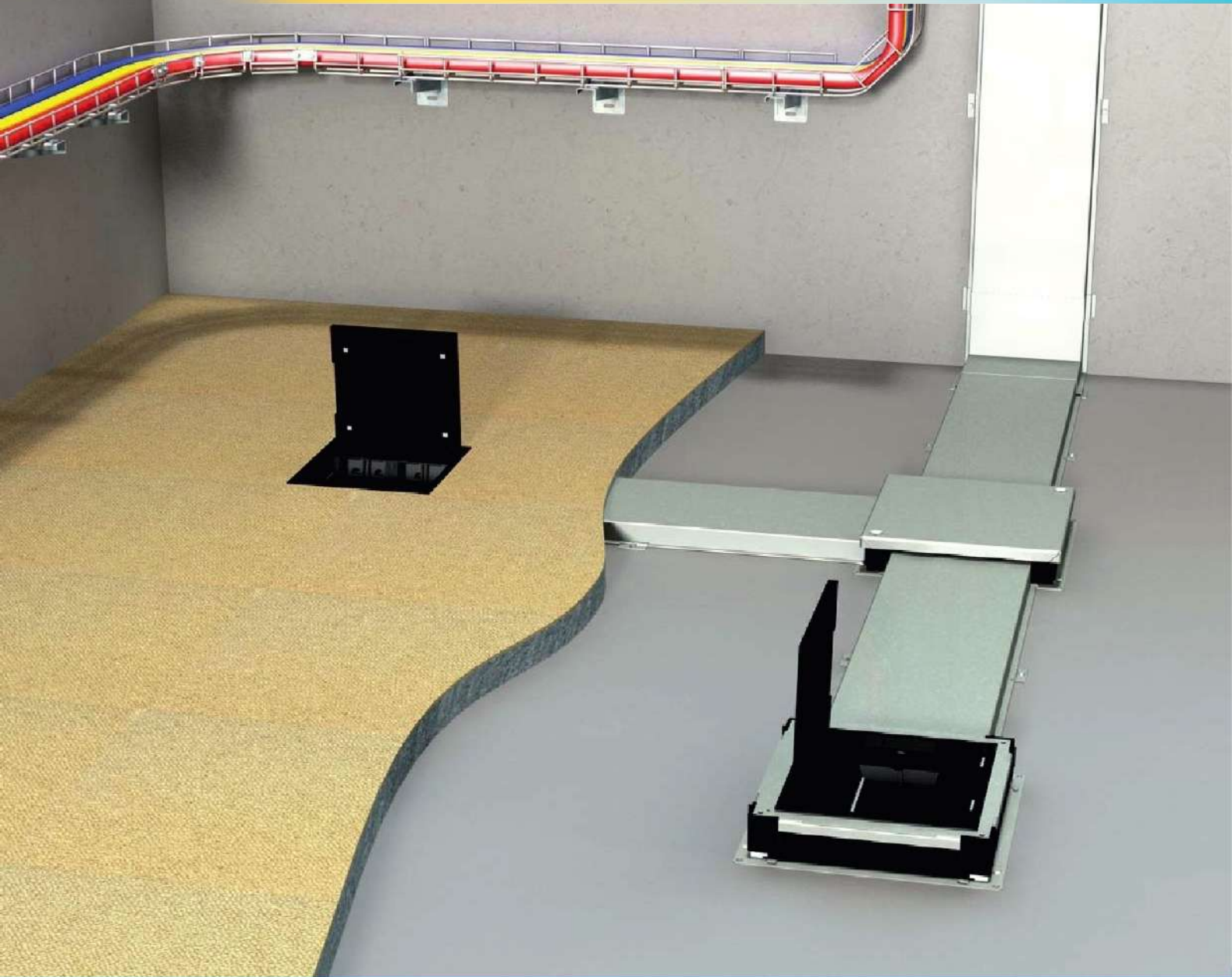

UNDERFLOOR CABLE TRAYS

UNDERFLOOR CABLE TRAYS H:30 - H:40

2 = PLAIN TYPE

ORDER CODE	A mm	H mm	T mm	L mm
UT-2-8H1.2L-?	80	30-40	1.25	2000-3000
UT-2-12H1.2L-?	120	30-40	1.25	2000-3000
UT-2-16H1.2L-?	160	30-40	1.25	2000-3000
UT-2-20H1.2L-?	200	30-40	1.25	2000-3000
UT-2-24H1.2L-?	240	30-40	1.25	2000-3000
UT-2-30H1.2L-?	300	30-40	1.25	2000-3000

NOTES:

1. (?) **H.D.G:** Hot dip galvanized
P.G: Pre galvanized
C: Colored

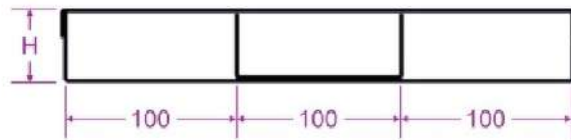
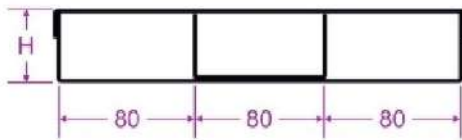
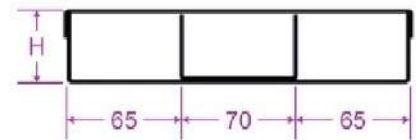
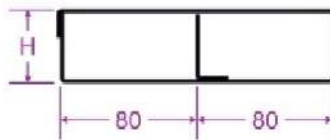
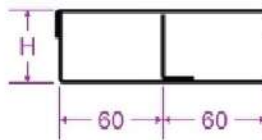
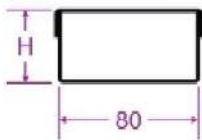
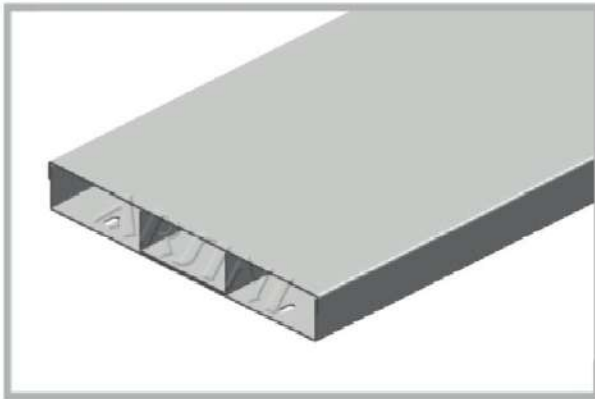
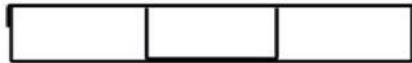

4 = 90° INSIDE FLANGE

ORDER CODE	A mm	H mm	T mm	L mm
UT-4-8H1.2L-?	80	30-40	1.25	2000-3000
UT-4-12H1.2L-?	120	30-40	1.25	2000-3000
UT-4-16H1.2L-?	160	30-40	1.25	2000-3000
UT-4-20H1.2L-?	200	30-40	1.25	2000-3000
UT-4-24H1.2L-?	240	30-40	1.25	2000-3000
UT-4-30H1.2L-?	300	30-40	1.25	2000-3000

NOTES:

1. (?) **H.D.G:** Hot dip galvanized
P.G: Pre galvanized
C: Colored

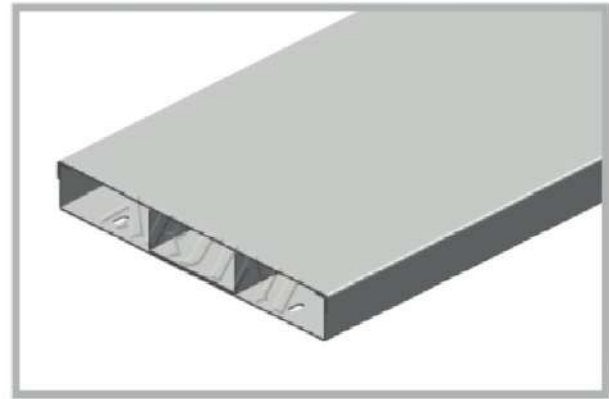

1- Straight connectors

ORDER CODE	A mm	H mm	T mm	L mm
UT1-8H1.2-?	83	15-25	1.25	80
UT1-12H1.2-?	123	15-25	1.25	80
UT1-16H1.2-?	163	15-25	1.25	80
UT1-20H1.2-?	203	15-25	1.25	80
UT1-24H1.2-?	243	15-25	1.25	80
UT1-30H1.2-?	303	15-25	1.25	80

NOTES:

1. (?) **H.D.G:** Hot dip galvanized
P.G: Pre galvanized
C: Colored

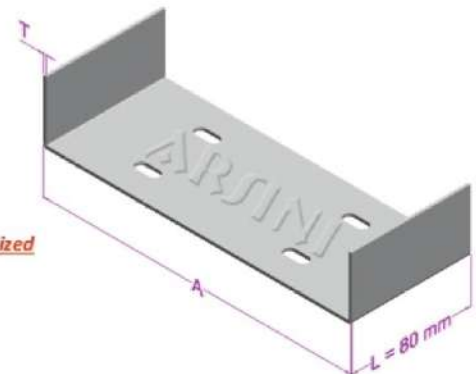

2- Inside vertical bend 90° degree

NOTES :

1- Each inside vertical bend 90° need 2 straight connector.

2- (?) --> H.D.G : Hot dip galvanized

P.G : Pre galvanized

C : colored

ORDER CODE	A mm	H mm	T mm	L mm
UT2-8H1.2L-?	80	30-40	1.25	400
UT2-12H1.2L-?	120	30-40	1.25	400
UT2-16H1.2L-?	160	30-40	1.25	400
UT2-20H1.2L-?	200	30-40	1.25	400
UT2-24H1.2L-?	240	30-40	1.25	400
UT2-30H1.2L-?	300	30-40	1.25	400

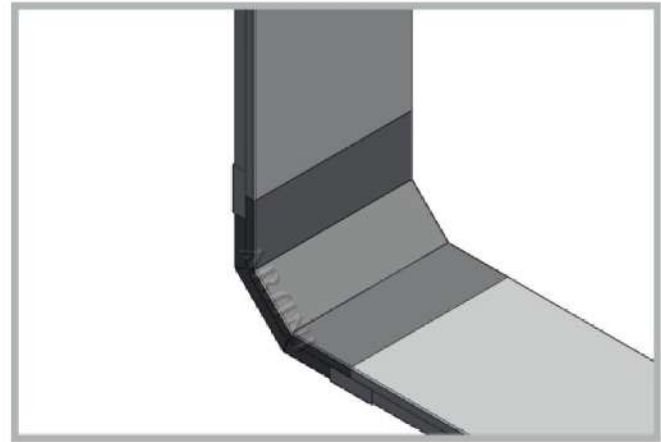
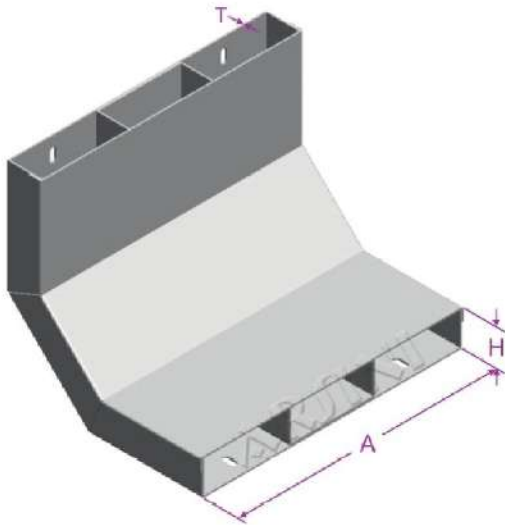

Connection Example

3- Horizontal bend 90° degree

NOTES :

1- Each horizontal bend 90° need 2 straight connector.

2- (?) --> H.D.G : Hot dip galvanized

P.G : Pre galvanized

C : colored

ORDER CODE	A mm	H mm	T mm
UT3-8H1.2L-?	80	30-40	1.25
UT3-12H1.2L-?	120	30-40	1.25
UT3-16H1.2L-?	160	30-40	1.25
UT3-20H1.2L-?	200	30-40	1.25
UT3-24H1.2L-?	240	30-40	1.25
UT3-30H1.2L-?	300	30-40	1.25

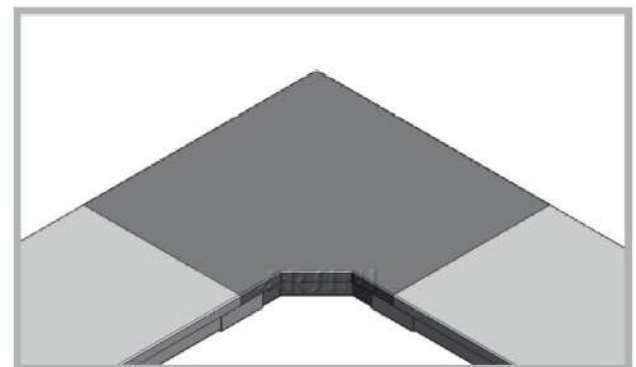
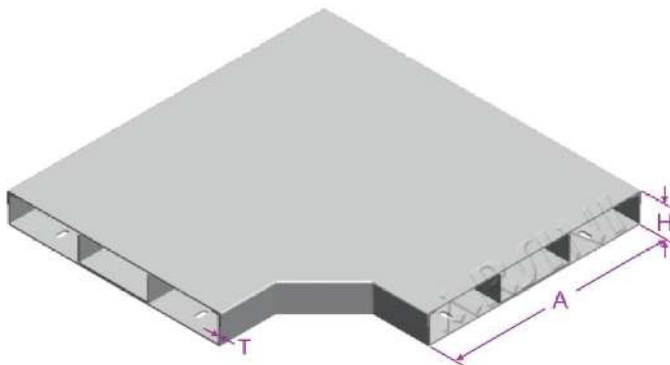

Connection Example

UNDERFLOOR CABLE TRAYS JUNCTION BOX

4- Junction box (underfloor 4 socket box)

NOTES :

1- The socket box doors made by two metal.

(?) --> AL : Aluminum

SS: Stainless steel

ORDER CODE	A mm	B mm	H mm	T mm
JB-AL	200	200	100	1.25
JB-SS	200	200	100	1.25



Junction box aluminum



Junction box stainless steel



ARSINI®

کل جریان با ما



www.barghzoom.com

